

# Figure A

## Table saw system

Overall Dimensions:  
72" long x 66" wide x 35" high

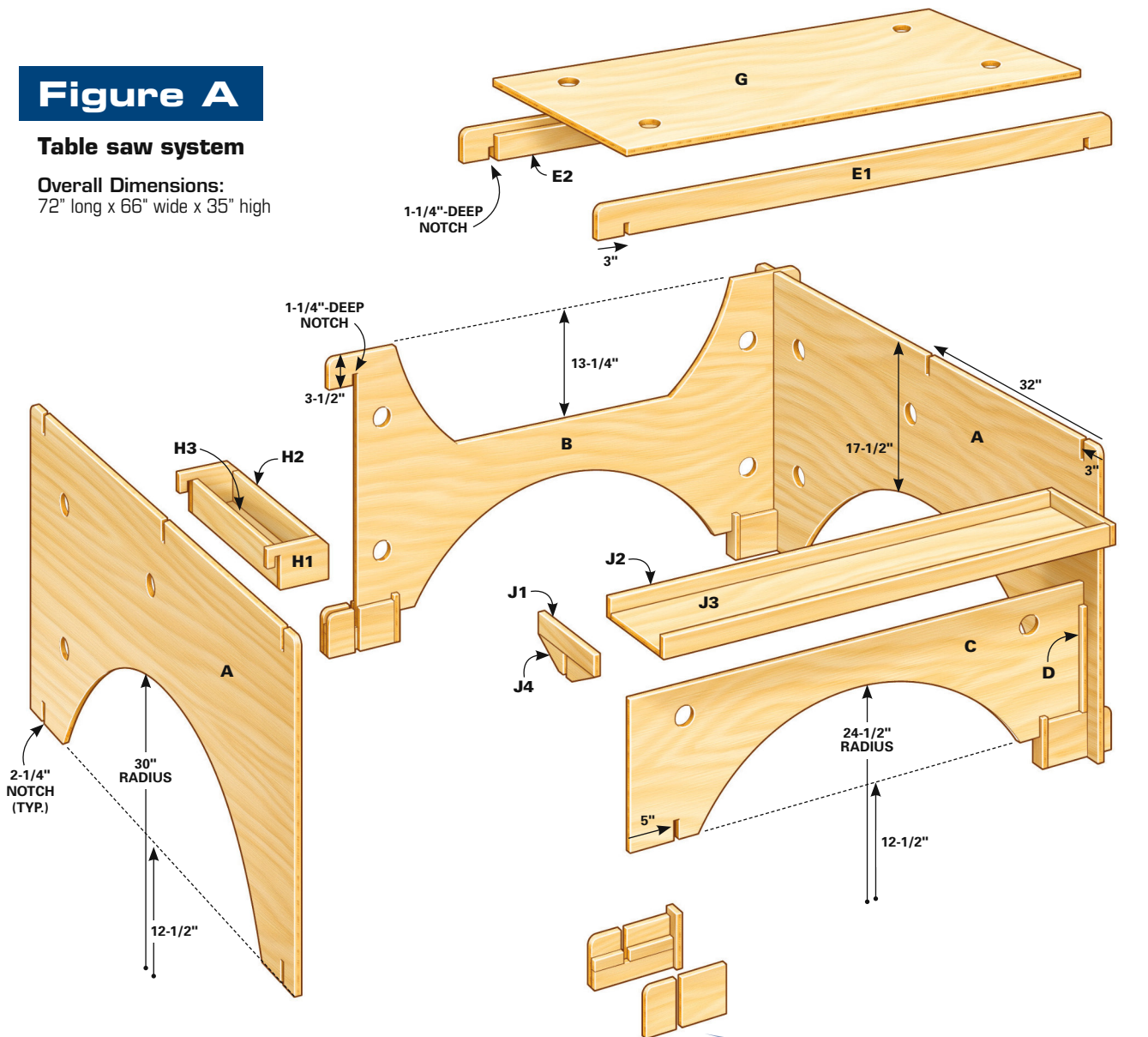

## Cutting List All 3/4" plywood

KEY	PCS.	SIZE & DESCRIPTION
A	2	35" x 72" plywood sides
B	1	31-1/2" x 66" plywood front panel
C	1	18-1/2" x 58-1/2" plywood end panel
D	4	3/4" x 17" plywood cleats
E1	2	3-1/2" x 66" plywood struts
E2	2	2-3/4" x 58-1/2" plywood strut supports
F1	4	9-1/4" x 2" plywood foot core
F2	4	1-1/4" x 5" plywood foot filler
F3	4	1-1/4" x 3-1/2" plywood foot filler
F4	8	5" x 5" plywood foot panel
F5	8	5" x 3-1/2" plywood foot panel
F6	4	2-3/16" x 5-5/8" plywood foot end panel
G	1	27-1/2" x 58-1/2" plywood outfeed top
H1	2	5" x 8-1/4" plywood tray end panels
H2	2	4" x 24" plywood tray end panels
H3	1	5" x 24" plywood tray bottom
J1	2	2-1/4" x 11-1/2" plywood tray end panel
J2	2	2-1/4" x 54" plywood tray side panel
J3	1	10" x 54" plywood tray bottom
J4	4	2-1/4" x 5-1/4" shelf brackets

